

HUNGER

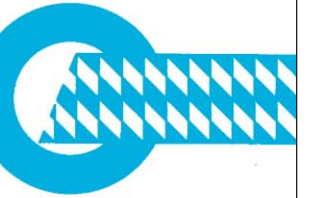

Catalog K21

Adjustable Reamers



Ludwig Hunger Werkzeug- und Maschinenfabrik GmbH

Postal Address
Postfach 70 09 60
81309 Munich
Germany

Street Address
Graefelfinger Str. 146
81375 Munich
Germany

Contact and Information
Tel +49 89 7091 25
sales@ludwig-hunger.de
www.ludwig-hunger.de



Experience

Performance

Quality

HUNGER - a company with experience - specializing in the manufacture of precision tools for over 95 years - and with the most comprehensive range of expanding reamers.

Years ago, **HUNGER** pioneered precision expanding reamers which have been further developed and refined until we have the present high performance tools.







The qualities of **HUNGER** tools are derived from close control of the materials and the manufacturing processes and the experience gained by **HUNGER** in over 95 years of precision tool manufacture.

HUNGER expanding reamers have been tested and approved by leading companies and are being used for high performance work throughout the world. Today's exacting tolerances and finishes call for **HUNGER** tools.

You can rely on **HUNGER**.

HUNGER manufactures also a comprehensive range of valve and valve seat refacing tools and machines for servicing the valves and valve seats of automotive engines and of large marine and stationary diesel engines.

Please feel free to ask for further information.

<p>Adjustable Reamers Type D for simple reaming jobs</p>		<p>Pages 4 - 5</p>
<p>Adjustable Reamers Type E with extra long blades</p>		<p>Pages 6 - 7</p>
<p>Adjustable Reamers Type K with single pilot</p>		<p>Pages 8 - 9</p>
<p>Adjustable Reamers Type U with double pilots</p>		<p>Pages 10 - 12</p>
<p>Adjustable Reamers Type V for valve guides</p>		<p>Page 13</p>
<p>Adjustable Reamers Type H for a series of aligned holdes</p>		<p>Pages 14 - 17</p>
<p>Reaming Practice</p>		<p>Page 18</p>

Type D

Design:

Righthand cutting reamer with adjustable blades.

Due to the unique Hunger relief grinding operation the blades have a progressively increasing clearance angle giving a softer cutting action.

Starting with size D 12 one of the adjusting nuts is marked with a circular scale. One graduation of the scale corresponds to an alteration of the reamer diameter by 0,01 mm.

Application:

The standard reamer for repair and assembly jobs.

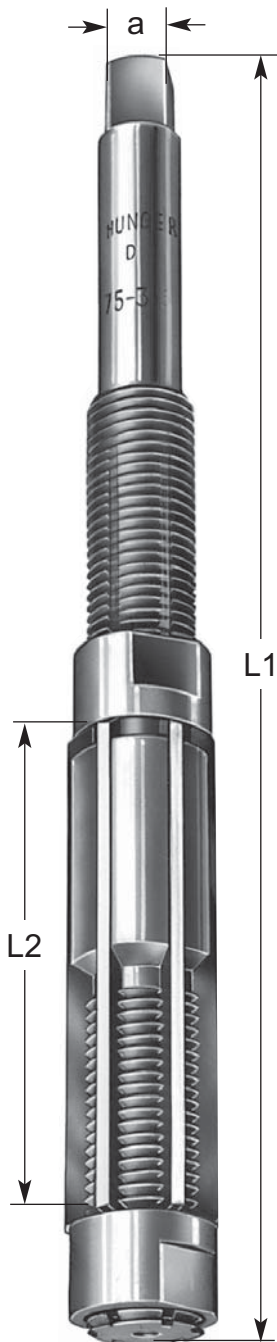

Size	Size Range		Length Overall L1 mm	Length Blades L2 mm	Size of Square a mm	No. of Blades	Weight kg
	mm	Inches					
D 6,4	6,4 - 7,2	1/4 - 9/32	111	32	3	4	0,015
D 7,2	7,2 - 8	9/32 - 5/16	111	32	3,5	4	0,015
D 8	8 - 9	5/16 - 23/64	111	32	4,3	5	0,025
D 9	9 - 10	23/64 - 25/64	115	32	4,3	5	0,035
D 10	10 - 11	25/64 - 7/16	120	35	4,9	5	0,040
D 11	11 - 12	7/16 - 15/32	125	35	6,2	5	0,045
D 12	12 - 13,5	15/32 - 17/32	130	42	6,2	5	0,075
D 13,5	13,5 - 15,5	17/32 - 39/64	145	50	7	5	0,100
D 15,5	15,5 - 18	39/64 - 45/64	165	60	8	5	0,155
D 18	18 - 21	45/64 - 53/64	180	65	9	5	0,225
D 21	21 - 24	53/64 - 15/16	190	70	10	5	0,320
D 24	24 - 27,5	15/16 - 1 5/64	205	75	11	5	0,430
D 27,5	27,5 - 31,5	1 5/64 - 1 15/64	225	80	12	6	0,600
D 31,5	31,5 - 37	1 15/64 - 1 29/64	240	90	14,5	6	0,870
D 37	37 - 45	1 29/64 - 1 49/64	285	100	16	6	1,410
D 45	45 - 55	1 49/64 - 2 5/32	320	109	20	6	2,320
D 55	55 - 65	2 5/32 - 2 9/16	350	120	24	8	3,830
D 65	65 - 80	2 9/16 - 3 5/32	460	145	29	10	6,800
D 80	80 - 95	3 5/32 - 3 47/64	490	150	32	10	10,250
D 95	95 - 110	3 47/64 - 4 21/64	490	150	36	10	13,700

Packing of the reamers:

From size D 6,4 to D 45 individually in clear plastic tubes.

Size D 55 in a plastic net.

From size D 65 to D 95 individually in wooden boxes.

Sets of Reamers Type D in Wooden Cases

Symbol	Size Range		No. of Reamers	Weight kg
	mm	Inches		
DAN	8 - 31,5	21/64 - 1 15/64	11	3,100
DEN	8 - 45	21/64 - 1 49/64	13	5,700

Type D

Order Information:

The reamers are fitted with blades made from high quality special steel to ensure superior cutting efficiency.

The production of reamers with hard chromium coated blades and of hard chromium coated replacement blades has been discontinued.
Remainders of stock are available as long as stock last.

Size	Size Range mm	Reamers		Replacement Blades*		Nuts Part No.
		Special Steel Part No.	Hard Chromium Part No.	Special Steel Part No.	Hard Chromium Part No.	
D 6,4	6,4 - 7,2	100 06 000	101 06 000	100 06 400	101 06 400	140 02 510
D 7,2	7,2 - 8	100 07 000	101 07 000	100 06 400	101 06 400	140 04 510
D 8	8 - 9	100 08 000	101 08 000	100 08 400	101 08 400	100 08 510
D 9	9 - 10	100 09 000	101 09 000	100 09 400	101 09 400	100 09 510
D 10	10 - 11	100 10 000	101 10 000	100 10 400	101 10 400	100 10 510
D 11	11 - 12	100 11 000	101 11 000	100 11 400	101 11 400	100 11 510
D 12	12 - 13,5	100 12 000	101 12 000	100 12 400	101 12 400	100 12 520
D 13,5	13,5 - 15,5	100 13 000	101 13 000	100 13 400	101 13 400	100 13 520
D 15,5	15,5 - 18	100 15 000	101 15 000	100 15 400	101 15 400	100 15 520
D 18	18 - 21	100 18 000	101 18 000	100 18 400	101 18 400	100 18 520
D 21	21 - 24	100 21 000	101 21 000	100 21 400	101 21 400	100 21 520
D 24	24 - 27,5	100 24 000	101 24 000	100 24 400	101 24 400	100 24 520
D 27,5	27,5 - 31,5	100 27 000	101 27 000	100 27 400	101 27 400	100 27 520
D 31,5	31,5 - 37	100 31 000	101 31 000	100 31 400	101 31 400	100 31 520
D 37	37 - 45	100 37 000	101 37 000	100 37 400	101 37 400	100 37 520
D 45	45 - 55	100 45 000	101 45 000	100 45 400	101 45 400	100 45 520
D 55	55 - 65	100 55 000	101 55 000	100 55 400	101 55 400	100 55 520
D 65	65 - 80	100 65 000	101 65 000	100 65 400	101 65 400	100 65 520
D 80	80 - 95	100 80 000	101 80 000	100 80 400	101 80 400	100 80 520
D 95	95 - 110	100 95 000	101 95 000	100 95 400	101 95 400	100 95 520

* Replacement blades are furnished in sets.
The blades are finish-ground and, therefore, no grinding is needed after the blades have been inserted in the reamer body.

Sets of Reamers Type D in Wooden Cases

Symbol	Size Range mm	Special Steel Part No.	Hard Chromium Part No.
DAN	8 - 31,5	100 00 100	101 00 100
DEN	8 - 45	100 00 200	101 00 200



Design:

Righth-hand cutting reamer with adjustable blades.

Extra long blades!

The blades are approximately 2/3 longer than the blades of reamer type D.

Due to the unique Hunger relief grinding operation the blades have a progressively increasing clearance angle giving a softer cutting action.

Application:

The reamer for reaming longer holes and adjacent inline holes.

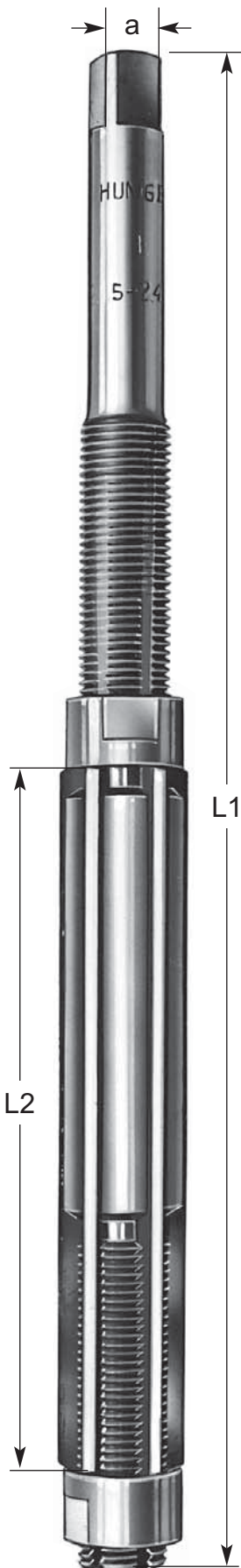

Size	Size Range		Length Overall	Length Blades L1 mm	Size of Square L2 mm	No. of Blades a mm	Weight kg
	mm	Inches					
E 10,5	10,5 - 12	27/64 - 15/32	160	65	5,5	5	0,070
E 12	12 - 13,5	15/32 - 17/32	170	70	6,2	5	0,100
E 13,5	13,5 - 15,5	17/32 - 39/64	195	80	7	5	0,140
E 15,5	15,5 - 17,5	39/64 - 11/16	215	90	8	5	0,210
E 17,5	17,5 - 19,5	11/16 - 49/64	230	100	9	5	0,280
E 19,5	19,5 - 21,5	49/64 - 27/32	240	110	10	5	0,370
E 21,5	21,5 - 24,5	27/32 - 31/32	260	120	10	5	0,470
E 24,5	24,5 - 27,5	31/32 - 1 5/64	280	130	11	5	0,640
E 27,5	27,5 - 31,5	1 5/64 - 1 15/64	310	140	12	6	0,880
E 31,5	31,5 - 37	1 15/64 - 1 29/64	320	150	14,5	6	1,240
E 37	37 - 45	1 29/64 - 1 49/64	370	165	16	6	1,970
E 45	45 - 55	1 49/64 - 2 5/32	425	180	20	6	3,240

Packing of the reamers:

Individually in clear plastic tubes.

Sets of Reamers Type E in Wooden Cases

Symbol	Size Range		No. of Reamers	Weight kg
	mm	Inches		
EA	10,5 - 31,5	27/64 - 1 15/64	9	3,100
ESO	10,5 - 45	27/64 - 1 49/64	11	5,700

Order Information:

The reamers are fitted with blades made from high quality special steel to ensure superior cutting efficiency.

The production of reamers with hard chromium coated blades and of hard chromium coated replacement blades has been discontinued.
Remainders of stock are available as long as stock last.

Size	Size Range mm	Reamers		Replacement Blades*		Nuts Part No.
		Special Steel Part No.	Hard Chromium Part No.	Special Steel Part No.	Hard Chromium Part No.	
E 10,5	10,5 - 12	110 10 000	111 10 000	110 10 400	111 10 400	110 10 510
E 12	12 - 13,5	110 12 000	111 12 000	110 12 400	111 12 400	100 12 510
E 13,5	13,5 - 15,5	110 13 000	111 13 000	110 13 400	111 13 400	100 13 510
E 15,5	15,5 - 17,5	110 15 000	111 15 000	110 15 400	111 15 400	100 15 510
E 17,5	17,5 - 19,5	110 17 000	111 17 000	110 17 400	111 17 400	110 17 510
E 19,5	19,5 - 21,5	110 19 000	111 19 000	110 19 400	111 19 400	110 19 510
E 21,5	21,5 - 24,5	110 21 000	111 21 000	110 21 400	111 21 400	100 21 510
E 24,5	24,5 - 27,5	110 24 000	111 24 000	110 24 400	111 24 400	100 24 510
E 27,5	27,5 - 31,5	110 27 000	111 27 000	110 27 400	111 27 400	100 27 510
E 31,5	31,5 - 37	110 31 000	111 31 000	110 31 400	111 31 400	100 31 510
E 37	37 - 45	110 37 000	111 37 000	110 37 400	111 37 400	100 37 510
E 45	45 - 55	110 45 000	111 45 000	110 45 400	111 45 400	100 45 510

* Replacement blades are furnished in sets.
The blades are finish-ground and, therefore, no grinding is needed after the blades have been inserted in the reamer body.

Sets of Reamers Type E in Wooden Cases

Symbol	Size Range mm	Special Steel Part No.	Hard Chromium Part No.
EA	10,5 - 31,5	110 00 100	111 00 100
ESO	10,5 - 45	110 00 200	111 00 200

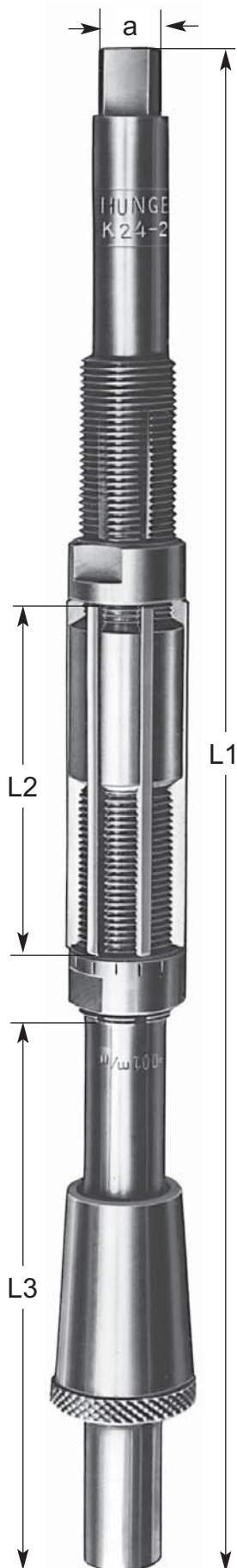

Type K

**Design:**

Righthand cutting reamer with adjustable blades.

Parallel shank with square at the back and integral pilot with sliding tapered guide sleeve at the front of the reamer.

Due to the unique Hunger relief grinding operation the blades have a progressively increasing clearance angle giving a softer cutting action.

Starting with size K 12 the adjusting nut is marked with a circular scale.

One graduation of the scale corresponds to an alteration of the reamer diameter by 0,01 mm.

Application:

The precision reamer for inline reaming of holes.

The tapered sleeve holds the reamer in exact alignment when reaming two holes.

Size	Size Range		Length Overall L1 mm	Length Blades L2 mm	Length Pilot L3 mm	Size of Square a mm	No. of Blades	Weight kg
	mm	Inches						
K 7	7 - 8	9/32 - 5/16	175	32	65	3,5	4	0,030
K 8	8 - 9	5/16 - 23/64	175	32	65	4,3	5	0,055
K 9	9 - 10	23/64 - 25/64	175	32	65	4,3	5	0,065
K 10	10 - 11	25/64 - 7/16	185	35	68	4,9	5	0,085
K 11	11 - 12	7/16 - 15/32	195	35	72	6,2	5	0,100
K 12	12 - 13,5	15/32 - 17/32	215	42	84	6,2	5	0,130
K 13,5	13,5 - 15,5	17/32 - 39/64	235	50	89	7	5	0,180
K 15,5	15,5 - 18	39/64 - 45/64	265	60	98	8	5	0,280
K 18	18 - 21	45/64 - 53/64	290	65	109	9	5	0,410
K 21	21 - 24	53/64 - 15/16	310	70	119	10	5	0,570
K 24	24 - 27,5	15/16 - 1 5/64	335	75	129	11	5	0,770
K 27,5	27,5 - 31,5	1 5/64 - 1 15/64	365	80	137	12	6	1,040
K 31,5	31,5 - 37	1 15/64 - 1 29/64	400	90	159	14,5	6	1,550
K 37	37 - 45	1 29/64 - 1 49/64	465	100	180	16	6	2,550
K 45	45 - 55	1 49/64 - 2 5/32	530	109	198	20	6	5,000
K 55	55 - 65	2 5/32 - 2 9/16	570	120	213	24	8	6,450
K 65	65 - 80	2 9/16 - 3 5/32	670	145	250	29	10	11,900
K 80	80 - 95	3 5/32 - 3 47/64	700	150	250	32	10	13,700
K 95	95 - 110	3 47/64 - 4 21/64	700	150	250	36	10	23,900

Packing of the reamers:

From size K 7 to K 37 individually in clear plastic tubes.

From size K 45 to K 55 individually in plastic nets.

From size K 65 to K 95 individually in wooden boxes.

Sets of Reamers Type K in Wooden Cases

Symbol	Size Range		No. of Reamers	Weight kg
	mm	Inches		
KAN	8 - 31,5	21/64 - 1 15/64	11	5,200
KEN	8 - 45	21/64 - 1 49/64	13	10,700

Order Information:

The reamers are fitted with blades made from high quality special steel to ensure superior cutting efficiency.

The production of reamers with hard chromium coated blades and of hard chromium coated replacement blades has been discontinued.

Remainders of stock are available as long as stock last.

Size	Size Range mm	Reamers		Replacement Blades*		Nuts Part No.	Tapered Guide Sleeve Part No.
		Special Steel Part No.	Hard Chromium Part No.	Special Steel Part No.	Hard Chromium Part No.		
K 7	7 - 8	120 07 000	121 07 000	100 06 400	101 06 400	140 04 510	120 07 600
K 8	8 - 9	120 08 000	121 08 000	120 08 400	121 08 400	100 08 510	120 08 600
K 9	9 - 10	120 09 000	121 09 000	120 09 400	121 09 400	100 09 510	120 09 600
K 10	10 - 11	120 10 000	121 10 000	120 10 400	121 10 400	100 10 510	120 10 600
K 11	11 - 12	120 11 000	121 11 000	120 11 400	121 11 400	100 11 510	120 11 600
K 12	12 - 13,5	120 12 000	121 12 000	120 12 400	121 12 400	100 12 520	120 12 600
K 13,5	13,5 - 15,5	120 13 000	121 13 000	120 13 400	121 13 400	100 13 520	120 13 600
K 15,5	15,5 - 18	120 15 000	121 15 000	120 15 400	121 15 400	100 15 520	120 15 600
K 18	18 - 21	120 18 000	121 18 000	120 18 400	121 18 400	100 18 520	120 18 600
K 21	21 - 24	120 21 000	121 21 000	120 21 400	121 21 400	100 21 520	120 21 600
K 24	24 - 27,5	120 24 000	121 24 000	120 24 400	121 24 400	100 24 520	120 24 600
K 27,5	27,5 - 31,5	120 27 000	121 27 000	120 27 400	121 27 400	100 27 520	120 27 600
K 31,5	31,5 - 37	120 31 000	121 31 000	120 31 400	121 31 400	100 31 520	120 31 600
K 37	37 - 45	120 37 000	121 37 000	120 37 400	121 37 400	100 37 520	120 37 600
K 45	45 - 55	120 45 000	121 45 000	120 45 400	121 45 400	100 45 520	120 45 600
K 55	55 - 65	120 55 000	121 55 000	120 55 400	121 55 400	100 55 520	120 55 600
K 65	65 - 80	120 65 000	121 65 000	100 65 400	101 65 400	100 65 520	120 65 600
K 80	80 - 95	120 80 000	121 80 000	100 80 400	101 80 400	100 80 520	120 80 600
K 95	95 - 110	120 95 000	121 95 000	100 95 400	101 95 400	100 95 520	120 95 600

* Replacement blades are furnished in sets.
The blades are finish-ground and, therefore, no grinding is needed after the blades have been inserted in the reamer body.

Sets of Reamers Type K in Wooden Cases

Symbol	Size Range mm	Special Steel Part No.	Hard Chromium Part No.
KAN	8 - 31,5	120 00 100	121 00 100
KEN	8 - 45	120 00 200	121 00 200

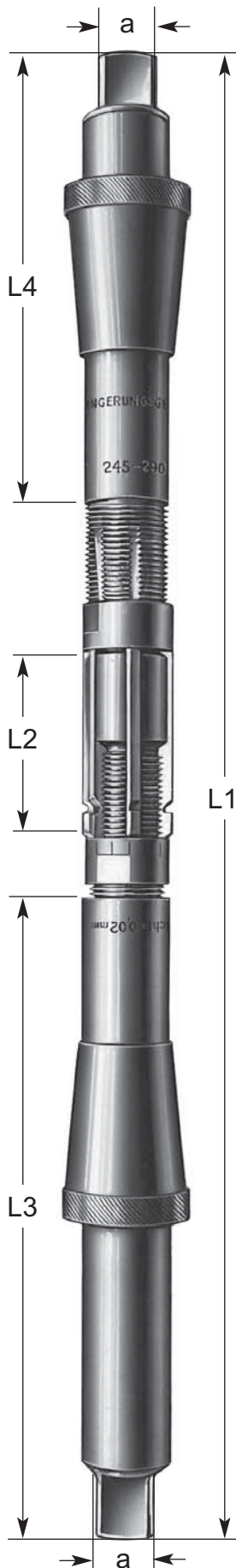

Type U

**Design:**

Righthand cutting reamer with adjustable blades.
 Exchangeable pilots at the front as well as at the back of the reamer.
 Each pilot is provided with square and sliding tapered guide sleeve.
 A special bayonet coupling with mating cones between each pilot and the reamer body ensures correct alignment. For extension pilots see page 12.
 The blades are ground for taking a rough cut followed by finish reaming.
 Due to the unique Hunger relief grinding operation the blades have a progressively increasing clearance angle giving a softer cutting action.
 The adjusting nut is marked with a circular scale.
 One graduation of the scale corresponds to an alteration of the reamer diameter by 0,02 mm.

Application:

The universal reamer for all types of holes, particularly for inline reaming of two or more holes.
 The tapered guides sleeve provide for exact alignment between the hole being reamed and an other mating hole.

Size	Size Range mm	Length Overall L1 mm	Length Blades L2 mm	Length Pilot L 3 mm	Length Pilot L 4 mm	Size of Square a mm	No. of Blades	Weight kg
U 12	12 - 13,5	250	30	110	82	8	5	0,170
U 13,5	13,5 - 15,5	270	33	116	84	9	5	0,245
U 15,5	15,5 - 18	295	36	127	88	10	5	0,360
U 18	18 - 21	330	40	140	100	12	5	0,545
U 19,5	19,5 - 22,5	352	44	150	110	13	5	0,700
U 21	21 - 24,5	352	44	150	110	13	5	0,800
U 24,5	24,5 - 29	385	48	157	118	13	6	1,140
U 29	29 - 34	418	52	170	130	16	6	1,670
U 34	34 - 39	440	54	180	140	18	6	2,430
U 39	39 - 45	475	60	190	150	18	6	3,310
U 45	45 - 52	500	60	200	162	18	6	4,700
U 52	52 - 59	500	60	200	162	18	6	5,700
U 59	59 - 66	500	60	200	162	18	6	6,700

Packing of the reamers:

From Size U 12 to U 39 individually in clear plastic tubes.
 From Size U 45 to U 59 individually in plastic nets.

Sets of Reamers Type U in Wooden Cases

Symbol	Size Range		No. of Reamers	Weight kg
	mm	Inches		
USI	12 - 34	$15/32 - 1 \frac{11}{32}$	7	6,700
USE	12 - 45	$15/32 - 1 \frac{49}{64}$	9	13,100

Type U

Order Information:

The reamers are fitted with blades made from high quality special steel to ensure superior cutting efficiency.

The production of reamers with hard chromium coated blades and of hard chromium coated replacement blades has been discontinued. Remainders of stock are available as long as stock last.

Size	Reamers		Replacement Blades*		Front Nut with Scale Part No.	Back Nut Part No.	Tapered Guide Sleeve Part No.
	Special Steel Part No.	Hard Chromium Part No.	Special Steel Part No.	Hard Chromium Part No.			
U 12	130 12 000	131 12 000	130 12 400	131 12 400	130 12 520	100 12 510	130 12 600
U 13,5	130 13 000	131 13 000	130 13 400	131 13 400	100 12 520	100 13 510	130 13 600
K 15,5	130 15 000	131 15 000	130 15 400	131 15 400	130 15 520	100 15 510	130 15 600
U 18	130 18 000	131 18 000	130 18 400	131 18 400	130 18 520	100 18 510	130 18 600
U 19,5⁺	130 19 000	131 19 000	130 19 400	131 19 400	100 18 520	130 19 510	130 19 600
U 21	130 21 000	131 21 000	130 21 400	131 21 400	130 21 520	100 21 510	130 21 600
U 24,5	130 24 000	131 24 000	130 24 400	131 24 400	130 24 520	130 24 510	130 24 600
U 29	130 29 000	131 29 000	130 29 400	131 29 400	130 29 520	130 29 510	130 29 600
U 34	130 34 000	131 34 000	130 34 400	131 34 400	130 34 520	130 34 510	130 34 600
U 39	130 39 000	131 39 000	130 39 400	131 39 400	130 39 520	130 39 510	130 39 600
U 45	130 45 000	131 45 000	130 45 400	131 45 400	130 45 520	100 45 510	130 45 600
U 52	130 52 000	131 52 000	130 45 400	131 45 400	130 52 520	130 52 510	130 52 600
U 59	130 59 000	131 59 000	130 45 400	131 45 400	130 52 520	130 52 510	130 59 600

* Replacement blades are furnished in sets. The blades are finish-ground and, therefore, no grinding is needed after the blades have been inserted in the reamer body.

⁺The intermediate size U 19,5 is not included in the sets.

Sets of Reamers Type U in Wooden Cases

Symbol	Size Range mm	Special Steel Part No.	Hard Chromium Part No.
USI	12 - 34	130 00 100	131 00 100
USE	12 - 45	130 00 200	131 00 200



Type U Pilots

Design:

Each pilot has a square at the one end and a female cone at the other end. The female cone in the pilot is designed to receive the mating male cone at the reamer body.

Pilot and reamer body are interlocked by a bayonet type coupling.

As the mating cones usually stick firmly together, the use of a plastic hammer is recommended to loosen the firm contact before removing the pilot from the reamer body. Apply light taps onto the pilot around the female cone. With the contact thus loosened, turn the pilot clockwise with respect to the reamer body until the triangular projection provided at the male cone is in the middle of the recess provided in the female cone. Then withdraw pilot from reamer body.

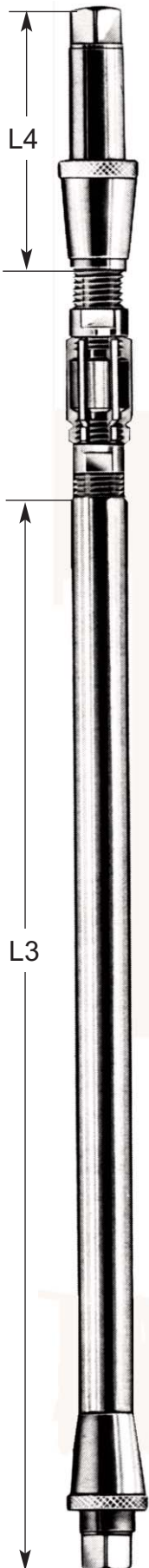

Size of Reamer	Standard Front Pilots		Standard Back Pilots		Extension Pilots Size I	
	Length L3 mm	Part No.	Length L4 mm	Part No.	Length mm	Part No.
U 12	110	130 12 701	82	130 12 702	210	132 12 711
U 13,5	116	130 13 701	84	130 13 702	220	132 13 712
U 15,5	127	130 15 701	88	130 15 702	230	132 15 713
U 18	140	130 18 701	100	130 18 702	240	132 18 714
U 19,5	150	130 19 701	110	130 19 702	250	132 19 715
U 21	150	130 21 701	110	130 21 702	250	132 21 715
U 24,5	157	130 24 701	118	130 24 702	260	132 24 716
U 29	170	130 29 701	130	130 29 702	270	132 29 717
U 34	180	130 34 701	140	130 34 702	280	132 34 718
U 39	190	130 39 701	150	130 39 702	290	132 39 719
U 45	200	130 45 701	162	130 45702	400	132 45 730
U 52	200	130 52 701	162	130 52 702	400	132 52 730
U 59	200	130 52 701	162	130 59 702	400	132 52 730

Size of Reamer	Extension Pilots Size II		Extension Pilots Size III		Extension Pilots Size IV	
	Length mm	Part No.	Length mm	Part No.	Length mm	Part No.
U 12	410	132 12 731	610	132 12 751	810	132 12 771
U 13,5	420	132 13 732	620	132 13 752	820	132 13 772
U 15,5	430	132 15 733	630	132 15 753	830	132 15 773
U 18	440	132 18 734	640	132 18 754	840	132 18 774
U 19,5	450	132 19 735	650	132 19 755	-	-
U 21	450	132 21 735	650	132 21 755	850	132 21 775
U 24,5	460	132 24 736	660	132 24 756	860	132 24 776
U 29	470	132 29 737	670	132 29 757	870	132 29 777
U 34	480	132 34 738	680	132 34 758	880	132 34 778
U 39	490	132 39 739	690	132 39 759	890	132 39 779
U 45	600	132 45 750	800	132 45 770	900	132 45 780
U 52	600	132 52 750	800	132 52 770	900	132 52 780
U 59	600	132 52 750	800	132 52 770	900	132 52 780

Special length extension pilots available on request.



Centering Bush

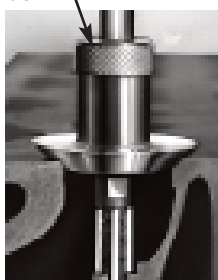

Design

Righth-hand cutting reamers with expanding blades, extra long shank with square and an optional centering bush.

Due to the unique Hunger relief grinding operation the blades have a progressively increasing clearance angle giving a softer cutting action.

Application

The special reamer for reaming the valve guides of combustion engines.

An optional centering bush is available for each reamer size. The centering bush fits firmly in the valve seat so that the reamer aligns perfectly with the bore.

Size	Reamers						Centering Bushes		
	Adjustment Range		Length overall L1 mm	Length blades L2 mm	Square a mm	Number of blades	Weight kg	Conicity mm	Weight kg
	mm	Inches							
V 5,4	5,4 - 6	7/32 - 15/64	160	28	4	3	0,025	14-21	0,030
V 5,9	5,9 - 6,5	15/64 - 1/4	160	28	4,3	3	0,030	17-28	0,050
V 6,4	6,4 - 7	1/4 - 17/64	160	28	4,9	3	0,035	16-28	0,050
V 6,9	6,9 - 7,5	17/64 - 19/64	160	28	5,5	3	0,040	21-38	0,070
V 7,4	7,4 - 8	19/64 - 5/16	165	28	5,5	3	0,045	22-36	0,065
V 7,9	7,9 - 8,5	5/16 - 21/64	170	28	6,2	3	0,055	23-47	0,150
V 8,4	8,4 - 9	21/64 - 23/64	175	28	6,2	3	0,065	28-44	0,155
V 8,9	8,9 - 9,5	23/64 - 3/8	180	32	7	4	0,075	25-53	0,190
V 9,4	9,4 - 10	3/8 - 25/64	190	32	7	4	0,085	26-52	0,180
V 9,9	9,9 - 11	25/64 - 7/16	200	36	8	5	0,100	25-53	0,190
V10,9	10,9 - 12	7/16 - 15/32	220	36	8	5	0,130	33-61	0,270

Order Information

The production of reamers with hard chromium coated blades and of hard chromium coated replacement blades has been discontinued. Remainders of stock are available as long as stock last.

Size	Reamers		Centering Bushes Part No.	Replacement Blades		Nuts Part No.
	Special Steel Part No.	Hard Chromium Part No.		Special Steel Part No.	Hard Chromium Part No.	
V 5,4	140 01 000	141 01 000	140 01 600	140 01 400	141 01 400	140 01 510
V 5,9	140 02 000	141 02 000	140 02 600	140 02 400	141 02 400	140 02 510
V 6,4	140 03 000	141 03 000	140 03 600	140 03 400	141 03 400	140 03 510
V 6,9	140 04 000	141 04 000	140 04 600	140 04 400	141 04 400	140 04 510
V 7,4	140 05 000	141 05 000	140 05 600	140 05 400	141 05 400	140 05 510
V 7,9	140 06 000	141 06 000	140 06 600	140 06 400	141 06 400	140 06 510
V 8,4	140 07 000	141 07 000	140 07 600	140 07 400	141 07 400	100 08 510
V 8,9	140 08 000	141 08 000	140 08 600	140 08 400	141 08 400	140 08 510
V 9,4	140 09 000	141 09 000	140 09 600	140 09 400	141 09 400	140 09 510
V 9,9	140 10 000	141 10 000	140 10 600	140 10 400	141 10 400	140 10 510
V10,9	140 11 000	141 11 000	140 11 600	140 11 400	141 11 400	140 11 510

* Replacement blades are furnished in sets. The blades are finish-ground and no grinding is needed after the blades have been inserted in the reamer body.

Boxed Sets of Reamers Type V

Type	Adjustment Range		Reamers Number	Bushes Number	Special Steel	Hard Chrom	Weight kg
	mm	Inches			Part No.	Part No.	
VR	5,9 - 12	15/64 - 15/32	10	-	140 00 100	141 00 100	1,140
VRB	5,9 - 12	15/64 - 15/32	10	10	140 00 200	141 00 200	3,500

Example of Application:
Inline Reaming of a Bearing Tunnel

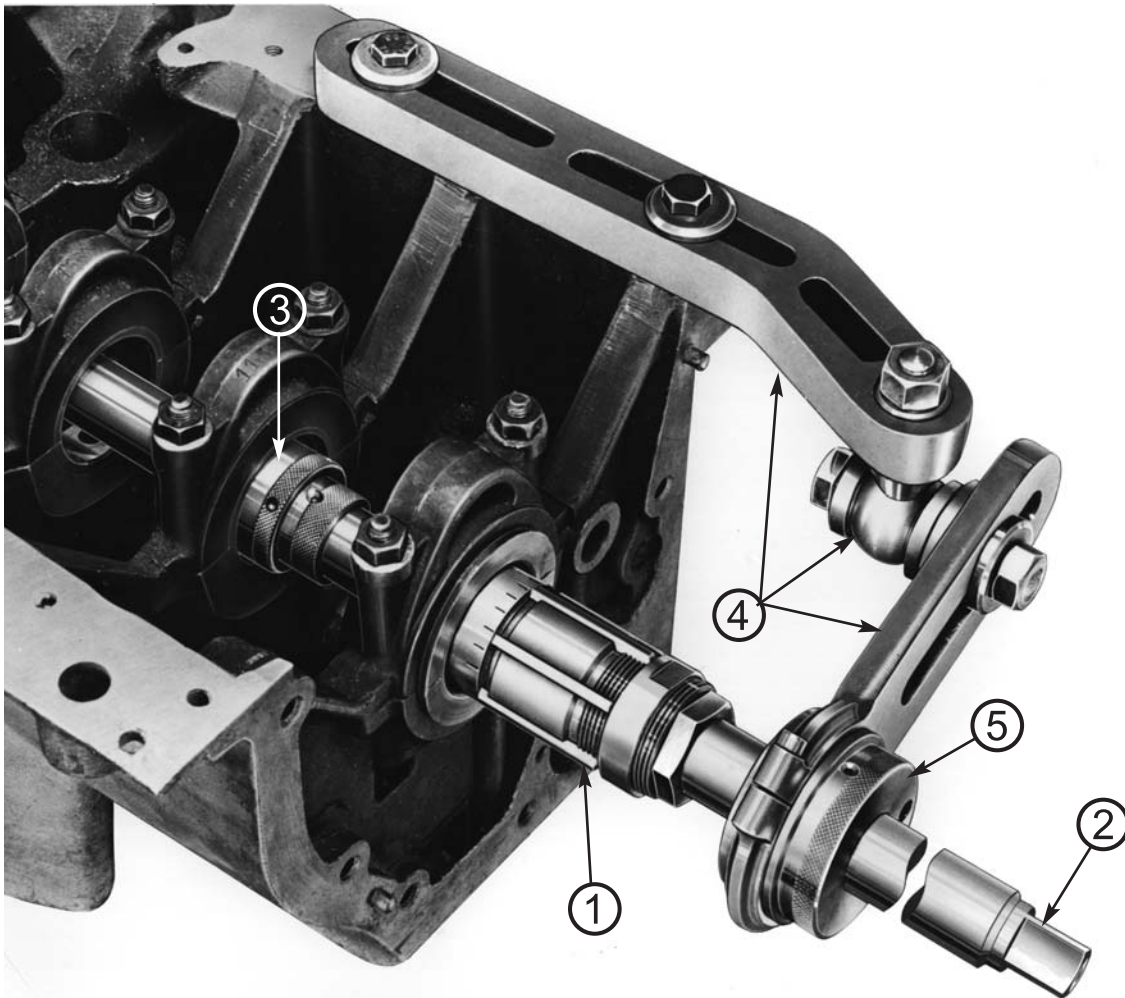

Components

- ① Adjustable Shell Reamer Type H
- ② Tool Bar
- ③ Expanding Tool Bar Guide
- ④ Additional Supporting Fixture
- ⑤ Guide Bush

Type H
Design:

Right-hand cutting shell reamer with adjustable blades.

The reamer fits on a tool bar and may be positioned along the tool bar at any desired position.

The reamer is automatically locked in place on the tool bar by an expanding clamping spring as soon as the reamer blades are brought into engagement with the hole.

Expanding tool bar guides and supporting fixtures for the tool bar are available to ensure exact alignment of the tool bar when reaming a series of aligned holes.

The nuts for adjusting the blades are marked with a circular scale.

One graduation of the scale corresponds to an alteration of the reamer diameter by 0,02 mm.

Application:

The reamer for inline reaming of a series of holes, particularly the holes of bearing tunnels..



Size	Size Range mm	Takes Tool Bar d mm	Length Overall L1 mm	Length Blades L2 mm	Nut SW mm	No. of Blades	Weight kg
H 36	36 - 38	20	96	44	32	6	0,370
H 38	38 - 41	20	99	44	34	6	0,450
H 41	41 - 44	20	104	48	38	6	0,590
H 44	44 - 47	25	104	48	40	6	0,590
H 47	47 - 51	25	108	48	43	6	0,760
H 51	51 - 54	30	108	52	47	5	0,830
H 54	54 - 58	30	113	52	47	6	0,930
H 58	58 - 62	30	113	52	53	6	1,180
H 62	62 - 65	35	114	52	58	8	1,290
H 65	65 - 69	35	118	57	58	8	1,490
H 69	69 - 73	40	118	57	64	8	1,790
H 73	73 - 78	40	123	57	68	8	1,990
H 78	78 - 83	45	124	57	70	8	2,110
H 83	83 - 88	45	124	60	78	8	2,750
H 88	88 - 93	50	124	60	83	8	3,000
H 93	93 - 99	50	127	60	83	10	3,490
H 99	99 - 105	50	127	60	*	10	4,200
H 105	105 - 111	50	127	60	*	10	5,040

* Adjustment of the nut with hook wrench.

**Order Information:**

The reamers are fitted with blades made from high quality special steel to ensure superior cutting efficiency.

The production of reamers with hard chromium coated blades and of hard chromium coated replacement blades has been discontinued.
Remainders of stock are available as long as stock last.

Size	Reamers		Replacement Blades*		Replacement Nuts		Replacement Springs Part No.
	Special Steel Part No.	Hard Chromium Part No.	Special Steel Part No.	Hard Chromium Part No..	Front Nut Part No.	Back Nut Part No.	
H 36	150 36 000	151 36 000	150 36 400	151 36 400	150 36 511	150 36 511	150 20 600
H 38	150 38 000	151 38 000	150 38 400	151 38 400	150 38 511	150 38 511	150 20 600
H 41	150 41 000	151 41 000	150 41 400	151 41 400	150 41 511	150 41 511	150 20 600
H 44	150 44 000	151 44 000	150 44 400	151 44 400	150 44 511	150 44 511	150 25 600
H 47	150 47 000	151 47 000	150 47 400	151 47 400	150 47 511	150 47 511	150 25 600
H 51	150 51 000	151 51 000	150 51 400	151 51 400	150 51 511	150 51 511	150 30 600
H 54	150 54 000	151 54 000	150 54 400	151 54 400	150 54 511	150 54 511	150 30 600
H 58	150 58 000	151 58 000	150 58 400	151 58 400	150 58 511	150 58 521	150 30 600
H 62	150 62 000	151 62 000	150 62 400	151 62 400	150 62 511	150 62 511	150 35 600
H 65	150 65 000	151 65 000	150 65 400	151 65 400	150 65 511	150 65 511	150 35 600
H 69	150 69 000	151 69 000	150 69 400	151 69 400	150 69 511	150 69 511	150 40 600
H 73	150 73 000	151 73 000	150 73 400	151 73 400	150 73 511	150 73 521	150 40 600
H 78	150 78 000	151 78 000	150 78 400	151 78 400	150 78 511	150 78 511	150 45 600
H 83	150 81 000	151 81 000	150 81 400	151 81 400	150 81 511	150 81 511	150 45 600
H 88	150 82 000	151 82 000	150 82 400	151 82 400	150 82 511	150 82 511	150 50 600
H 93	150 83 000	151 83 000	150 83 400	151 83 400	150 83 511	150 83 511	150 50 600
H 99	150 84 000	151 84 000	150 84 400	151 84 400	150 84 511	150 84 511	150 50 600
H 105	150 85 000	151 85 000	150 85 400	151 85 400	150 85 511	150 85 511	150 50 600

* Replacement blades are furnished in sets.

The blades are finish-ground and, therefore, no grinding is needed after the blades have been inserted in the reamer body.

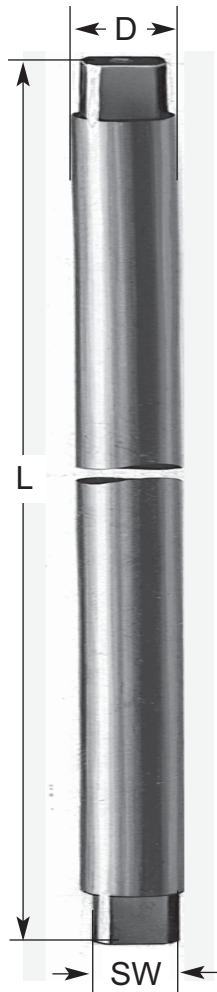

Tool Bars for Shell Reamers Type H

Design:

Precision ground bars provided with squares at both ends .
Standard types are listed below.
Special length guide bars on application.

Order Information:

Tool Bar		Diameter D mm	Length L mm	Square SW mm	Weight kg
Part No.	for Reamer Size				
152 20 101	H 36 - H 41	20	1000	13	2,420
152 25 101	H 44 - H 47	25	1000	13	3,740
152 30 121	H 51 - H 58	30	1200	16	6,540
152 30 151	H 51 - H 58	30	1500	16	12,000
152 35 121	H 62 - H 65	35	1200	18	8,750
152 40 151	H 69 - H 73	40	1500	18	14,400
152 45 151	H 78 - H 83	45	1500	22	18,110
152 50 171	H 88 - H 105	50	1700	22	25,200

* Other lengths on request.

Expanding Tool Bar Guides

Description:

The tool bar guides are provided with wedges which can be forced outward against the hole to lock the tool bar guide in the hole.
The wedges are actuated by an adjusting nut.

Order Information:

Tool Bar Guides			Bore d mm	Expansion Range D mm	Weight kg
Size	Part No.	Suitable for Reamer Sizes			
EL20	153 20 000	H 36 - H 41	20	35,5 - 54	0,200
EL25	153 25 000	H 44 - H 47	25	43,5 - 62	0,300
EL30	153 30 000	H 51 - H 58	30	49,5 - 74	0,410
EL35	153 35 000	H 62 - H 65	35	61,5 - 83	0,620
EL40	153 40 000	H 69 - H 73	40	68,5 - 93	0,800
EL45	153 45 000	H 78 - H 83	45	77,5 - 105	1,100
EL50	153 50 000	H 88 - H 105	50	87,5 - 127	1,550

Supporting Fixture for Tool Bars

Description:

The universal supporting fixture is designed to locate a tool bar guide bush in front of an end bearing hole for perfect alignment of the tool bar in centerline with the hole.

The guide bush is locked in a clamping arm which is connected by a ball joint to a mounting base which is attached to the cylinder block.

Both the clamping arm and the ball joint are adjustable to ensure proper alignment.

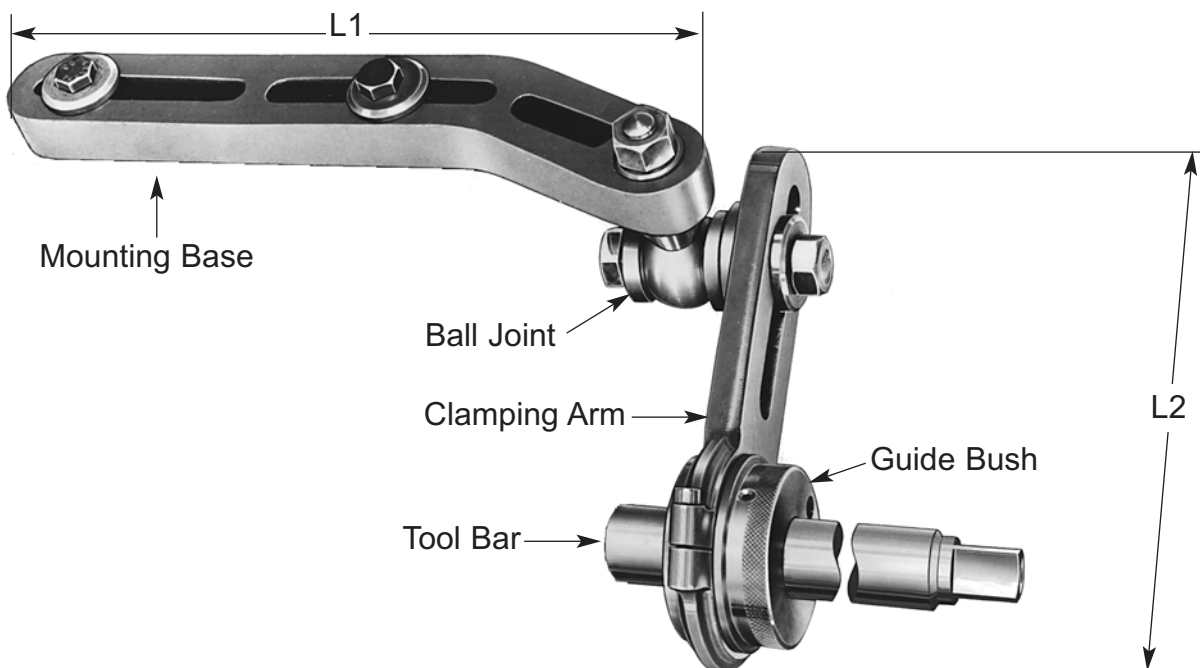

Order Information:

Size	Supporting Fixture		Individual Components of the Supporting Fixture						
	Part No.	Weight kg	Mounting Base			Clamping Arm		Ball Joint	
			Size	Part No.	L1 mm	Size	Part No.	L2 mm	Part No.
IA	156 11 100	3,140	IA	156 11 110	330	IA	156 11 120	210	156 11 130
IIA	156 12 100	5,100	IIA	156 12 110	400	IIA	156 12 120	270	156 11 130
IIA1	156 12 102	5,100	IIA	156 12 110	400	IA	156 11 120	210	156 11 130

Guide Bushes for Clamping Arm Size IA			
Size	Part No.	Bore Dia. for Bar	Weight kg
IA/20	156 21 200	20 mm	0,920
IA/25	156 21 250	25 mm	0,880
IA/30	156 21 300	30 mm	0,820
IA/35	156 21 350	35 mm	0,750
IA/40	156 21 400	40 mm	0,650
IA/45	156 21 450	45 mm	0,600
IA/50	156 21 500	50 mm	0,550

Guide Bushes for Clamping Arm Size IIA			
Size	Part No.	Bore Dia. for Bar	Weight kg
IIA/40	156 22 400	40 mm	1,940
IIA/45	156 22 450	45 mm	1,890
IIA/50	156 22 500	50 mm	1,800

Application.

Expanding reamers are designed to finish holes to an exact size or a precise fit where size is determined during assembly.

The blades cut away small amounts of material leaving an exactly round, precisely finished hole.

The amount of material to be removed by the reamers depends on the size of the hole and the material being reamed..

A common cutting allowance is 0,03 to 0,1mm per cut. In case of reamer type U the cutting allowance can be up to 0,3mm per cut.

Usually the more difficult the material being reamed the smaller the cutting allowance.

Removing too little stock, however, will tend to dull the blades because they will press the hole open rather than cut.

A rough cut followed by finish reaming will produce a better surface finish than reaming holes in a single operation.

Size Adjustment.

The precision ground reamer blades are retained by nuts in slots milled with a taper.

Adjustment is a simple operation carried out by loosening of one nut while tightening the other, thus allowing the blades to progress along the tapered bottom slots resulting in an increase or decrease of the reamer diameter according to the direction of adjustment.

Reamers with an even number of blades can be checked for size with a micrometer.

Reamers with an odd number of blades can be set to size by first adjusting the reamer to a known size bushing or ring and then using the scale of the adjusting nut to set the reamer to the final size.

Using Reamers.

To set up for reaming, select the correct size reamer and adjust the blades to the required diameter.

Place reamer in the hole to be reamed and apply moderate axial pressure so that the blades have cutting contact with the hole from the beginning. Attach the tap holder to the square shank.

The tap holder must precisely fit onto the square to ensure that the reamer shank is securely held. Check alignment of the reamer. Alignment should be 90° to the surface. Verify alignment with a square.

Using tap holder, turn reamer clockwise (in direction of cutting) while applying even pressure to advance the reamer through the hole.

Important.

The Reamers must always be turned clockwise (in the direction of cutting) even when removing from the hole.

Never turn a reamer counter-clockwise!

Turning the reamer counter-clockwise in the hole dulls the blades.

When reaming deep holes withdraw the reamer from time to time to clear the chips.

While withdrawing the reamer always turn the reamer clockwise.

When reaming through the back end of the hole reduce pressure to make sure the reamer is not pushed through the hole but rather the back end of the hole is being reamed with the same feed and speed as the main portion.

When removing the reamer from the hole turn the reamer clockwise to avoid damage of the reamed hole and dulling of the reamer blades.

Lubrication.

Use of a cutting fluid will improve the finish and prolong the life of the reamer in many cases.

When reaming iron and steel always lubricate with cutting oil or emulsion.

Use kerosene for reaming brass, bronze, aluminum and other soft metals.

Cast iron and malleable iron may be reamed perfectly dry.

Using Reamers with Guide Sleeves.

The tapered guide sleeve is seated in one hole guiding the reamer as it reams the other hole.

The guide sleeve provides for exact alignment between the hole being reamed and its mating hole.

As the blades ream the hole, the guide sleeve placed in the other hole or in the back end of a deep hole holds the reamer in exact alignment.

Maintenance of the Reamers.

Carefully clean reamers after use.

Store reamers in the clear plastic tube containers or in the wooden cases.

A light coating of oil will prevent corrosion and prolong the life.

If required, clean the blade slots from time to time to ensure correct adjustment of the cutting diameter. Remove each blade and slide the corner of the blade along the bottom of the slot to remove chips and dirt.